



## KK-60



### Brief Introduction

King Clima KK-60 model is direct engine driven 6KW cooling solutions for minibus or vans with 4-4.5m length.

### Features

- ◆ Compact design
- ◆ Cooling for special zone
- ◆ Independent installation
- ◆ Independent control and system

### Technical of KK-60 Minibus Air Conditioner

|                          |                                     |   |
|--------------------------|-------------------------------------|---|
| Model                    | KK-60                               |   |
| Cooling Capacity         | 6400W/5500Kcal/22000Btu             |   |
| Power Consumption (24V)  | <330W                               |   |
| Installation Type        | Rooftop Mounted                     |   |
| Driven Type              | Direct Engine Driven                |   |
| Max Operating Temp. (°C) | 50°C                                |   |
| Evaporator               | Type                                | Hydrophilic aluminum foil with internal ridge copper tube |
|                          | Air Flow Volume (m <sup>3</sup> /h) | 600m <sup>3</sup> /h                                      |
|                          | Fan Motor                           | 3-speed Centrifugal Type                                  |
|                          | No. Or Fan Motor                    | 2pc   |
| Condenser                | Type                                | Aluminum Foil with Internal Ridge Copper Tube             |
|                          | Air Flow Volume (m <sup>3</sup> /h) | 1800m <sup>3</sup> /h                                     |
|                          | Fan Motor                           | Axial Type  |
|                          | No. Or Fan Motor                    | 2pc   |
| Compressor               | Brand                               | Sanden China Compressor                                   |
|                          | Model                               | SD5H14  |
|                          | Displacement                        | 138cc/r   |
|                          | Compressor Oil Type                 | PAG100  |
|                          | Weight(KG)                          | 5KG   |
| Evaporator Blower        | 3-speed centrifugal type            |   |
| Condenser Fan            | Axial flow                          |   |
| Compressor               | Valeo TM21, 215 cc/r                |   |
| Refrigerant              | R134a                               |   |
| Length/Width/Height (mm) | 956*761*190                         |   |
| Weight (KG)              | 30                                  |   |
| Application              | 4-4.5m Minibus or Vans              |   |

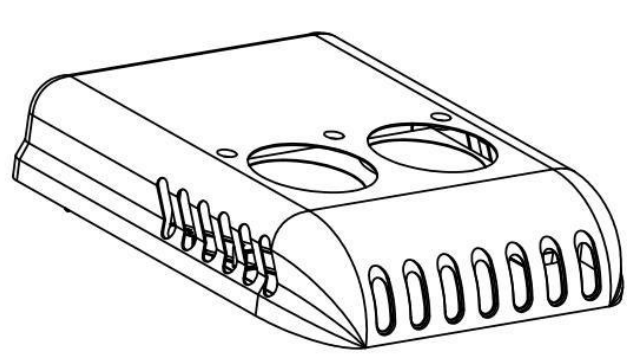
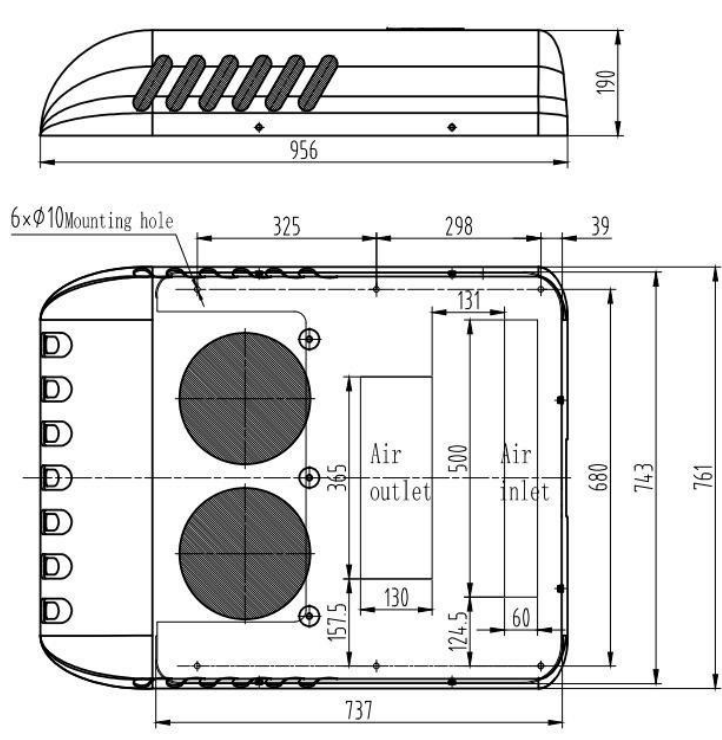

**Henan King Clima Industry**  
Best Cooling Solutions for Buses

Web: [www.kingclima.com](http://www.kingclima.com) Email: [info@kingclima.com](mailto:info@kingclima.com)  
Tel: 86-371-66379266 Fax: 86-371-66379166